

[54] **MOBILE, ARCTIC DRILLING AND PRODUCTION PLATFORM**

[75] Inventors: **George E. Mott, Metairie; James P. Wilbourn, New Orleans, both of La.**

[73] Assignee: **Texaco Inc., New York, N.Y.**

[22] Filed: **Oct. 18, 1971**

[21] Appl. No.: **189,972**

[52] U.S. Cl. **61/46.5**

[51] Int. Cl. **E02b 17/00**

[58] Field of Search..... **61/46.5, 46; 114/5 T**

Primary Examiner—Jacob Shapiro
Attorney, Agent, or Firm—Thomas H. Whaley; Carl G. Ries

[57] **ABSTRACT**

The invention relates to a marine platform adapted to be removably positioned at an offshore body of water, the surface of which is periodically subjected to sheet ice and floating ice masses. The platform includes a controllably buoyant foundation-like base at its lower end, which normally rests on the ocean floor. A shell-like body extends upwardly from said base and is defined on its external surface by a progressively decreasing cross sectional area from the body lower end, to a point adjacent the upper end. A work deck disposed at, and operably carried at the body upper end includes equipment necessary to function at said offshore site. A caisson extending uprightly through the platform is partially embedded into the substratum beneath the platform, firmly anchoring the latter and protecting wells during and after a drilling operation.

[56] **References Cited**
UNITED STATES PATENTS

2,574,140	11/1951	Boschen.....	61/46.5
3,486,343	12/1969	Gibson et al.....	61/46.5
2,622,404	12/1952	Rice.....	61/46.5
3,408,821	11/1968	Redshaw.....	61/46.5
3,645,104	2/1972	Hogan.....	61/46.5
2,661,600	12/1953	Hopkins.....	61/46.5
3,165,898	1/1965	Elliott.....	61/46.5

5 Claims, 4 Drawing Figures

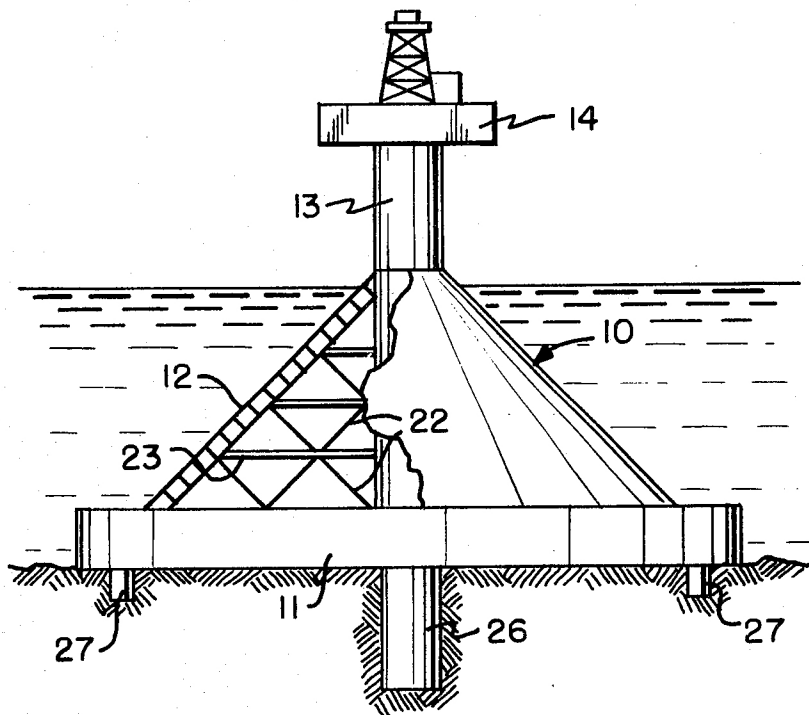

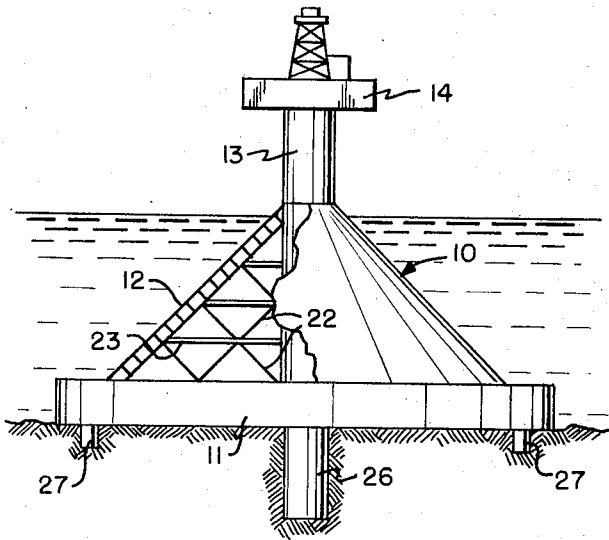

FIG. 1

FIG. 2

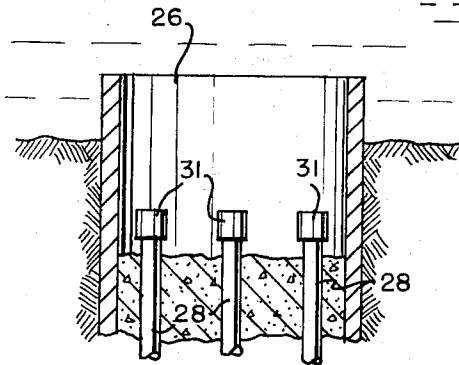
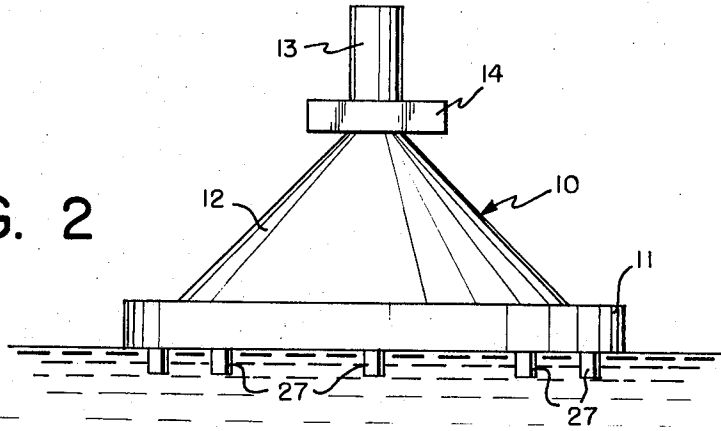
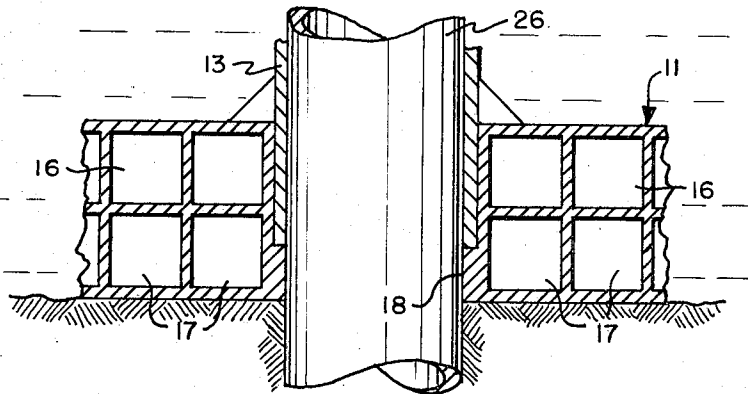

FIG. 4

FIG. 3



MOBILE, ARCTIC DRILLING AND PRODUCTION PLATFORM

BACKGROUND OF THE INVENTION

A marine platform of the type presently disclosed can serve many purposes and be utilized by a number of industries. In the specific instance of the petroleum industry, the platform is generally positioned in an off-shore body of water to drill into and explore the sub-stratum for the possibility of producing crude oil and gas. Normally, in water depths up to several hundred feet such marine platforms are fixed to the drilling site by piles of similar retaining means.

In the instance of such marine platforms built for use in Arctic tideland waters, the problem of rigid positioning of the unit is compounded by the presence of floating ice during certain periods of, and sometimes for most of the year, the presence of large ice floes as well as moving sheet ice, virtually prohibit the use of any sort of conventional fixed platform.

On the other hand in more protected areas such as Alaska's Cook Inlet, the problem of sheet ice which moves with the tide can be met to a degree by incorporating into the platform specific features to overcome the conditions prompted by the presence of the moving ice.

One method found to be suitable for opposing the lateral thrust of a moving ice mass, whether in the form of floes or an entire ice field, is by fabricating a platform with sufficient mass and with an adequate degree of stability to physically resist the displacing forces exerted on the structure. Such platforms however as a rule are of a relatively permanent nature in that once they are installed at a particular site they are not amenable to be subsequently readily removed or to be reused in different water depths. Thus, if the site proves to be nonproductive, the use of an expensive nonsalvageable platform would result in excessive operating expense.

In addition to the stated problems of initially drilling wells in ice infested waters, the subsequently drilled wells and well head equipment are further jeopardized by heavy ice floes. Ice floes are known to reach to the ocean floor and be of such a magnitude as to scour and dig out the latter. This results in the subjecting to bending, breaking off or otherwise damaging, any sea floor equipment installed in such an environment. Even though the said equipment be buried to a desired depth beneath the ocean floor, it may still be susceptible to physical damage when extraordinary size icebergs or the like are in the area.

It is therefore economical and desirable to utilize a fixed type platform for offshore drilling under ice conditions, and yet provide such a platform that is mobile and can be reused in different water depths if it is determined that a particular area is nonproductive. This problem is suitably countered and overcome by the present marine apparatus. Said structure comprises in effect a platform adapted for drilling, producing or exploratory work in an offshore body of water in which moving ice is prevalent.

The platform is provided with a relatively widespread foundation-like base to afford a firm footing. Further, it is made salvageable such that the platform can be removed from a particular spot and subsequently reset at

an alternate drilling or producing location. The platform embodies a downwardly extending heavy walled caisson through which the respective wells are drilled. Said caisson is of sufficient strength and rigidity to resist installation forces and to protect the wells during the drilling operation. When the platform is removed, the caisson may be left in place and thus serves as a well protector. The platform is physically contoured along its exterior particularly along the level at which ice would be concentrated, such as to expose a minimum area thereof to contact with moving ice.

DESCRIPTION OF THE DRAWINGS

FIG. 1 is a vertical elevation in partial cross section of the instant marine structure shown submerged and anchored at an underwater site.

FIG. 2 is similar to FIG. 1 illustrating the platform when buoyed to a floating position.

FIG. 3 is a segmentary view in cross section showing a portion of the structure shown in FIG. 1.

FIG. 4 is an enlarged segmentary view showing a well head installation subsequent to removal of the anchoring caisson.

Referring to FIG. 1, a platform 10 of the type contemplated is shown installed at the floor of an offshore body of water. Base 11 comprises in general a circular, octagonal or other multisided barge-like unit disposed at the lower end of the platform, which member ordinarily assumes a horizontal disposition. Base 11 supports an upstanding, conically shaped shell or body 12 having a contoured external surface which connects a relatively broad lower section to a relatively constricted narrow portion at the upper end. Body 12 is further provided with an upwardly extending column 13 along which an equipment deck 14 is operably received. Thus, when the platform is submerged at a working site, deck 14 can be raised or lowered to a desired height beyond the water's surface. Further, when the platform is installed at a drilling site, either the upper end of said shell 12 or column 13 is disposed adjacent to the water's surface whereby to meet, break up and deflect moving ice at the water's surface.

Base member 11 comprises in effect a barge-like vessel formed of a plurality of closed, individually controlled tanks. By regulation of the buoyancy of the respective tanks, the attitude and disposition of the base can be readily regulated between the ocean floor and the water's surface. Base 11 is preferably formed with welded steel or reinforced concrete sections of sufficient strength and so reinforced, as to resist external forces and pressures expected in the depths of water where the platform would normally be positioned. The respective compartments such as 16 and 17 within base 11 are individually separated by discretely placed bulkheads and panels. Thus, selective adjustment of the buoyancy of said compartments results in the platform being raised or lowered to a desired depth or positioned at a desired attitude.

While not presently shown, each compartment 16 and 17 is connected with a buoyancy system regulated from the water's surface and adapted to urge a fluid medium such as water or drilling mud through the respective compartments as required. Said system of course includes means for regulating the flow of said fluids to achieve the purpose of raising or adjusting the level of the barge.

An opening 18 extends transversely and centrally of barge 11, communicating the upper and lower surfaces thereof in a generally vertical disposition.

Elongated, conically shaped shell 12 is disposed with its center axis normal to base 11, extending into and being rigidly connected to the latter. Column 13 also connects to and extends axially through conical shell 12 and base 11. The respective members are thus secured one to the other in a manner to form a rigid, upright structure. The relationship between said members not only assembles the respective parts into a unitary component, but transfers or applies shear stress and overturning loads applied to column shell exterior, to the widespread base 11. A suitable fastening means between base 11 and shell 12 may be provided by fabricating the shell 12 of reinforced concrete whereby to achieve a satisfactory bonded engagement between the body peripheral lower edge, and the base.

Base 11 is further provided with means to assure its fixed positioning at a desired offshore working site. Thus, said base includes not only center transverse opening 18, but optionally may include openings adapted to receive a plurality of relatively short spud piles 27 which can be driven through the base to engage or be embedded into the substratum after the platform comes to rest on the latter.

The lower edge of conical shell 12 is secured to base 11 and maintains the shell in a substantially upright disposition. One embodiment of said shell comprises a hollow, heavy walled unit formed of reinforced concrete, steel, or a combination of said materials. Preferably, the shell is made in the form of a geometrically conical member characterized by an outer wall surface having a horizontal cross section which decreases as the distance from base 11 increases.

The primary function of conical shell or body 12 is to provide a relatively widespread footing for the platform in conjunction with base 11. Further, said body is provided with a sloping outer contour or surface to best encounter moving sheet ice whereby to deflect the latter upwardly, causing it to break into smaller pieces due to induced bending stresses. While not presently shown in detail, compartments built into the interior of shell 12 are vented to the atmosphere to better control the internal and external pressures while the platform is being submerged.

Elongated, cylindrical column 13 extends coaxially of shell 12 from the point adjacent to base 11 to which it is fastened, to a point beyond the shell 12 upper end. Thus column 13 projects upwardly for a substantial distance beyond the shell upper end when platform 10 is resting on the floor of an offshore drilling site. The primary function of said column is to operably support work deck 14 during the transportation of the platform as well as to provide a means of elevating the work deck 14 a desired distance beyond the water's surface during actual drilling operations.

Column 13 thus comprises an elongated cylindrical member formed of relatively heavy walled steel or reinforced concrete. The column lower end is received in receptacle means forming opening 18 in base 11 and is fastened to the latter by cementing, welding, or other appropriate means. The upper end of shell 12 is further fastened to the outer wall of column 13 to fixedly join the entire assembly into a unitary structure. Intermediate support means such as struts, braces 22 and 23 or bulkheads are further disposed within body 12 and ra-

diate outwardly from the column wall to reinforce both the shell and the column, and to permit ballasting of the conical shell 12 as needed.

Toward facilitating movement of deck 14 longitudinally along the column 13 exterior, either to the upper or lower position, the column can be provided with the necessary slots, indentations, protrusions or the like. Said means facilitate gripping of the column wall by a plurality of climbing jacks and claps carried within deck 14. Such jacks are clamps known in the art and are frequently utilized on mobile offshore structures for regulating the disposition of retractable legs carried on the marine platform or structure.

Subsequent to platform 10 being submerged at a desired offshore location, a caisson 26, which has previously been secured inside column 13 and extends longitudinally thereof, is released and jetted into the sea bottom. Base 11 is thus firmly embedded in the substratum beneath the platform quickly and easily without the use of either piles or anchor. A sufficient embedment of said caisson 26 will assist platform 10 in absorbing and transmitting to the ocean bottom, lateral forces imposed on the structure, thus further insuring against the possibility of lateral displacement of the platform.

As shown in FIG. 3, caisson 26 extends preferably in a downward direction through the center of the platform to achieve the desired anchoring function. Further, in connection with a drilling or producing operation, and as shown in FIG. 4, when it is deemed feasible to move the platform, column 13 is free to slide along the embedded portion of caisson 26 as the platform is raised by ballasting.

In such position, the lower remaining end of the caisson serves as a protector or enclosure for both wells and well head equipment at the floor of the drilling site.

In the event that icebergs of other relatively deep ice masses tend to scour the floor of the ocean in the vicinity of submerged wells 28, the protruding portion of caisson 26 will form a barrier about said wells. Should caisson 26 nonetheless be contacted by a floating iceberg in a manner to bend or deform the caisson walls, the internal wells 28 would still be protected due to their position within the caisson which will tend to bend rather than fracture as they are displaced by the ice mass.

Caisson 26 is initially assembled with platform 10 during fabrication of the latter. Thus, it can be floated to the drill site by the buoyant platform. It is appreciated that since caisson 26 will be lowered or driven into the substratum, it will be necessary to add additional caisson sections if the platform is moved to other locations. A number of caisson sections would thus be carried, ancillary to the platform placing operation.

As shown in FIG. 3, when in the installed position, the lower end of caisson 26 is disposed contiguous with walls of the column 13 extending through the shell lower surface. If it is desired to permanently place a platform at a desired location, means may also be provided for cementing or otherwise rigidly fastening the shell 12 upper and lower ends to the casing to rigidize the disposition thereof and to avoid movement in response to pressure exerted against the platform.

As shown in FIG. 1, subsequent to the platform being anchored into position, deck 14 is elevated along column 13 outer surface, beyond the water's surface a predetermined height to facilitate drilling operation and to

maintain deck carried equipment beyond the reach of the anticipated waves and ice.

As shown in FIG. 4, wells 28 may be completed with subsea well heads 31 or extended to the deck elevation for conventional surface cntrols, or may be capped for future use. In the latter event, such equipment may be embedded below the surface of the substratum as a form of protection. In such instance, the remaining, protruding portion of caisson 26 will serve to enclose said well head and equipment until such time as the wells are connected to the surface for producing petroleum fluids.

Subsequent to said drilling operation as noted, platform 10 is separated from caisson 26 by ballasting the latter to raise it a predetermined distance beyond the ocean floor. The platform will then slide upwardly along caisson 26 in an orderly, controlled manner. Thereafter, by controlled flotation of the base 11 and venting of body 12, the platform can be entirely raised from its position and refloated to an alternate working site.

I claim:

1. A marine platform adapted to be removably positioned at an offshore body of water, the latter being in an environment subject to floating ice, which platform includes;

a submergible base including buoyancy means incorporated therein for controllably regulating the disposition of said base between the floating position at the water's surface, and a resting position at the floor of said body of water, said base having means forming a vertical transverse opening there-through, a guide column having upper and lower ends, the latter being fixed to and extending upwardly from said base in alignment with said vertical transverse opening, the column upper end being of sufficient length to extend beyond the water's surface when said base is positioned at said

floor,

a caisson disposed internally of and contiguous with said guide column, extending longitudinally thereof and having the lower end embedded into the substrate beneath said platform whereby to anchor the latter during a drilling operation, and to subsequently permit upward guided movement of said platform along the caisson when the platform is raised from a submerged position,

an elongated shell characterized by a generally conical external surface, having the broad end connected to said base and having the upper constricted end in engagement with said guide column adjacent the upper end thereof, and

a deck operably carried on said guide column upper end being longitudinally movable therealong for positioning a desired distance beyond the water's surface.

2. A marine platform as defined in claim 1, including a caisson operably received in said guide column and longitudinally movable through the latter whereby to permit lowering of said caisson downwardly through said base to permit embedment thereof into the floor of said body of water.

3. In an apparatus as defined in claim 2, wherein said guide column is of substantially uniform diameter and slidable along said caisson outer surface to guide the latter during lowering thereof into the substrate.

4. In an apparatus as defined in claim 1, wherein said conical shell is of sufficient height to position at least a portion thereof beyond the water's surface when said base is resting at said floor.

5. In a marine platform as defined in claim 1, wherein said caisson extends upwardly along said guide column to position with the upper end thereof adjacent to and beneath the water's surface.

* * * * *

40

45

50

55

60

65